



## Speed Queen Home Retail Front Washer Softmount

### AFNE9BSP305LW01

#### Built better to last longer

From the mechanically rolled brushed finish on the hood to the 1 million button pushes during testing, you know the outside is as solid and reliable as the inside. Our electronic controls are the most durable on the market. In fact, the controls manufactured for home use are the same controls you'll find in laundromats, hotels, and other commercial applications.



#### A proven performer

Speed Queen laundry equipment is designed for commercial use and applies the same technology and commercial grade components to all of our models intended for use in the home. Our machines are tested to 10,400 cycles. When you take into consideration that the average user washes 8 loads per week, 52 weeks per year, that equates to 10,400 cycles or 25 years in the average home.

#### Commercial Grade Controls

Laundry is all we do, and we do it better than anyone else in the world. For decades, we've been designing, building and testing controls the same way we do our machines: for unmatched, longer-lasting performance. Tested to endure through virtually every event that typically causes malfunction, Huebsch controls are durably designed to last in the harshest commercial environments — and last even longer in your home. We're so confident in our controls that we back our electronic models with an industry-best warranty on all parts and in-home labor.



## Specifications

# Speed Queen Home Retail Front Washer Softmount

Model	AFNE9BSP305LW01
General details	
Control	HEC
Control location	Front 45 degree
Actuation	None
Drum	
Capacity kg	10,5
Volume l	96,8
Drum speed	
G-factor	440
Extraction RPM	1200
Power	
Motor power kW	0,67
Voltage	220-240/50/1
Cabinet	
Cylinder Finish	Stainless
Color	White
Door type	Window
Connections	
Electrical requirements	220-240/50/1
Water inlet	3/4"
Water Pressure kPa	1,4-8,3
Transport data	
Net weight kg	118
Shipping weight kg	122
Dimensions HxWxD mm	1091 x 683 x 704
Packed dimensions HxWxD mm	1156 x 762 x 864
Packed volume m3	0,76

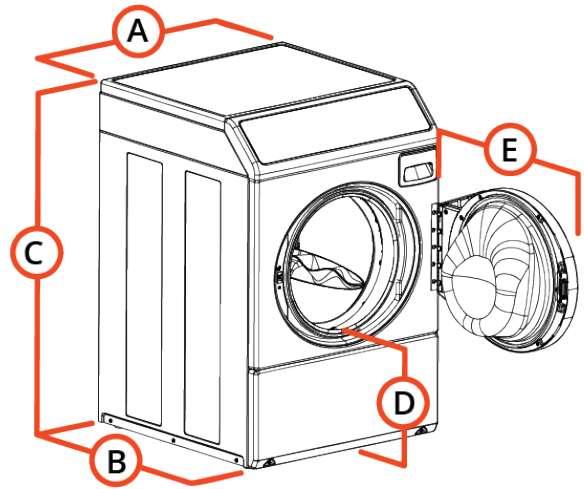

## Dimensions

	mm
A	683
B	704
C	1091
D	371
E	610